

APPROVAL SPECIFICATION

PRODUCT NAME: _____

KOOMAG PN: KMTTC0624 Series _____

CUSTOMER PN: _____

CUSTOMER RESPONSE

<input type="checkbox"/> Approval <input type="checkbox"/> Approval with the following changes <input type="checkbox"/> Reject		
APPROVED BY	SIGNATURE	DATE

KOOMAG ENGINEERING SIGNATURE

APPROVED BY	CHECKED BY	ISSUED BY
DATE	DATE	DATE

深圳坤磁科技有限公司

SHENZHEN KOOMAG TECHNOLOGY CO., LTD

Address: B503, Building B, HuaChuangDa Headquarters Building, Bao'an 49 District, Shenzhen

General Description

This specification applies to the KMTC0624 Series of wire wound SMD power inductor.

Appearance & Shape

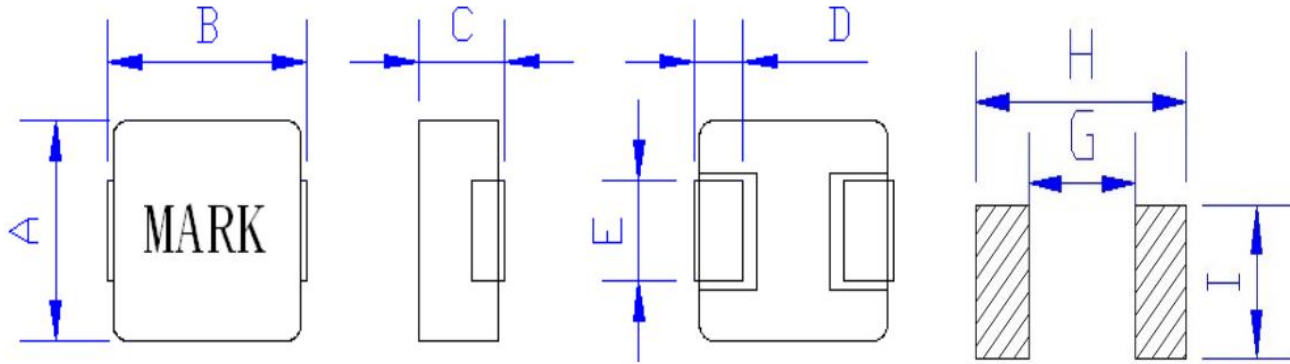

Dimension (Unit:mm)

NO	Series	A	B	C	D	E	G	H	I
1	KMTC0624	6.6 ±0.3	7.1±0.5	2.4 Max	1.6±0.5	3.0±0.3	2.9 Ref.	7.8 Ref.	3.5 Ref.

Part Number

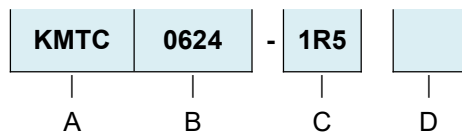

A:Series name (产品品名)

B:Dimensions (产品尺寸)

C:Inductance value (电感值) 1R5: 1.5μH 220: 22μH

D:Tolerance (误差值) K: ±10%; M: ±20%; N: ±30%

Electrical Characteristics

Please refer to Item 5.

- 1). Operating temperature range (individual chip without packing): $-40^{\circ}\text{C} \sim +125^{\circ}\text{C}$.
- 2). Storage temperature range (packaging conditions): $-40^{\circ}\text{C} \sim +85^{\circ}\text{C}$ and RH 70% (Max.).
- 3). Rating DC current: Temperature rise(ΔT) is 40°C approximately at Irms.
- 4). Saturation DC current: Inductance drop approximately 30% of L0 at Isat.

NO	Part Number	Inductance	DC Resistance		Saturation Current	Temp.Rise current	Marking
		100KHz/1.0V	Max.	Typ.	Typ.	Typ.	
	Units	(μH)	m Ω	m Ω	A	A	
1	KMTC0624-R22M	0.22 \pm 20%	3.6	2.4	30.0	15.0	R22
2	KMTC0624-R47M	0.47 \pm 20%	7.5	5.0	18.0	10.0	R47
3	KMTC0624-R68M	0.68 \pm 20%	10	6.9	16.0	9.0	R68
4	KMTC0624-1R0M	1.00 \pm 20%	13	11	15.0	7.0	1R0
5	KMTC0624-1R5M	1.50 \pm 20%	24	16	13.0	6.5	1R5
6	KMTC0624-2R2M	2.20 \pm 20%	40	26	10.0	6.0	2R2
7	KMTC0624-3R3M	3.30 \pm 20%	50	34	9.0	5.0	3R3
8	KMTC0624-4R7M	4.70 \pm 20%	60	41	7.0	4.0	4R7
9	KMTC0624-6R8M	6.80 \pm 20%	95	64	6.5	3.0	6R8
10	KMTC0624-100M	10.00 \pm 20%	120	87	4.5	2.0	100
11							
12							
13							
14							
15							
16							
17							
18							
19							
20							

※Design as Customer's Requested Specifications. (可按顾客的特殊需求设计)

Packaging(unit:mm)

1.Tape Dimensions(Unit:mm)

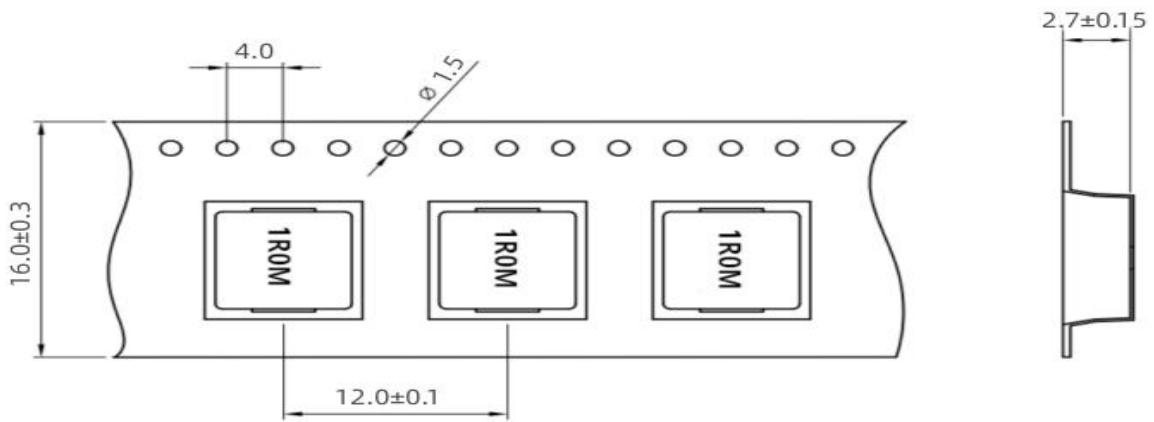

2.Reel

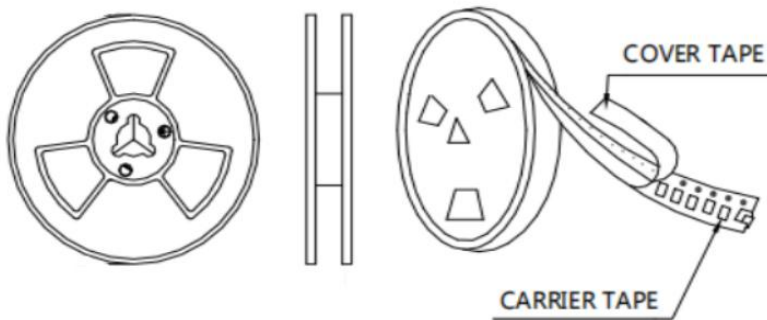

Part No.	Tape	MPQ
KMTC0624	Embossed Tape	2000PCS

Soldering Condition Sproduct

Applicable soldering process to the products is refl.

1.Soldering Materials

(1)Solder:Sn-3.0Ag-0.5Cu

(2)Flux:Use rosin-based flux,but not strongly acidic flux (with xhlorine exceeding 0.2wt%).Do not use water-soluble flux.

2.Reflow Soldering Profile

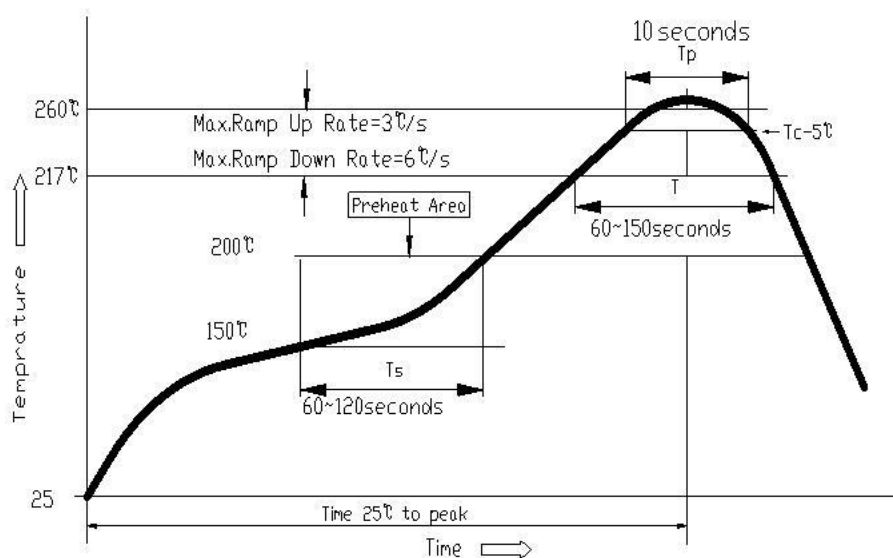

3.Solderin glron

Reworking with electric soldering iron must preheating at 150°C for 1 minute is required,and do not directly touch the core with the tip of the soldering iron.The reworking soldering conditions are as follows.

- ①Temperature of soldering iron tip:350°C ;
- ② Soldering iron power output:≤30W;
- ③ Diameter of soldering iron end:≤1.0mm;
- ④Soldering time:< 3s.

