

APPROVAL SPECIFICATION

PRODUCT NAME:

KOOMAG PN:KMTC0620 Series

CUSTOMER PN:

CUSTOMER RESPONSE

<input type="checkbox"/> Approval <input type="checkbox"/> Approval with the following changes <input type="checkbox"/> Reject		
APPROVED BY	SIGNATURE	DATE

KOOMAG ENGINEERING SIGNATURE

APPROVED BY	CHECKED BY	ISSUED BY
DATE	DATE	DATE

深圳坤磁科技有限公司
 SHENZHEN KOOMAG TECHNOLOGY CO., LTD

Address: B503, Building B, HuaChuangDa Headquarters Building, Bao'an 49 District, Shenzhen

General Description

This specification applies to the KMTC0620 Series of wire wound SMD power inductor.

Appearance & Shape

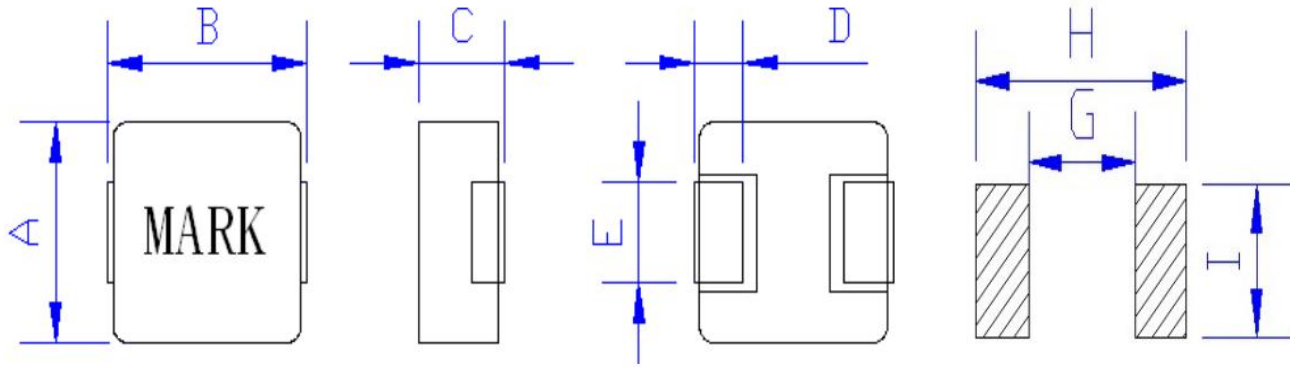

Dimension (Unit:mm)

NO	Series	A	B	C	D	E	G	H	I
1	KMTC0620	6.6 ±0.3	7.1±0.5	2.0 Max	1.6±0.5	3.0±0.3	2.9 Ref.	7.8 Ref.	3.5 Ref.

Part Number

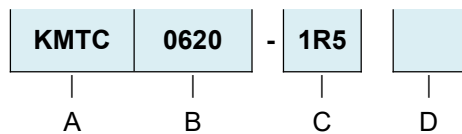

A:Series name (产品品名)

B:Dimensions (产品尺寸)

C:Inductance value (电感值) 1R5: 1.5μH 220: 22μH

D:Tolerance (误差值) K: ±10%; M: ±20%; N: ±30%

Electrical Characteristics

Please refer to Item 5.

- 1). Operating temperature range (individual chip without packing): $-40^{\circ}\text{C} \sim +125^{\circ}\text{C}$.
- 2). Storage temperature range (packaging conditions): $-40^{\circ}\text{C} \sim +85^{\circ}\text{C}$ and RH 70% (Max.).
- 3). Rating DC current: Temperature rise(ΔT) is 40°C approximately at Irms.
- 4). Saturation DC current: Inductance drop approximately 30% of L0 at Isat.

NO	Part Number	Inductance	DC Resistance		Saturation Current	Temp.Rise current	Marking
		100KHz/1.0V	Max.	Typ.	Typ.	Typ.	
	Units	(μH)	m Ω	m Ω	A	A	
1	KMTC0620-R22M	0.22 \pm 20%	4.5	2.6	25.0	13.0	R22
2	KMTC0620-R33M	0.33 \pm 20%	7.0	4.5	24.0	12.0	R33
3	KMTC0620-R47M	0.47 \pm 20%	10	6.8	20.0	10.0	R47
4	KMTC0620-R68M	0.68 \pm 20%	15	9.5	17.0	9.0	R68
5	KMTC0620-1R0M	1.00 \pm 20%	24	16.5	14.0	7.0	1R0
6	KMTC0620-1R5M	1.50 \pm 20%	36	24	12.0	6.0	1R5
7	KMTC0620-2R2M	2.20 \pm 20%	45	30	9.0	5.0	2R2
8	KMTC0620-3R3M	3.30 \pm 20%	95	44	7.0	4.0	3R3
9	KMTC0620-4R7M	4.70 \pm 20%	105	77	6.5	3.5	4R7
10	KMTC0620-6R8M	6.80 \pm 20%	128	101	4.0	2.0	6R8
11	KMTC0620-100M	10.00 \pm 20%	180	148	3.5	2.0	100
12							
13							
14							
15							
16							
17							
18							
19							
20							

※Design as Customer's Requested Specifications. (可按顾客的特殊需求设计)

Packaging(unit:mm)

1.Tape Dimensions(Unit:mm)

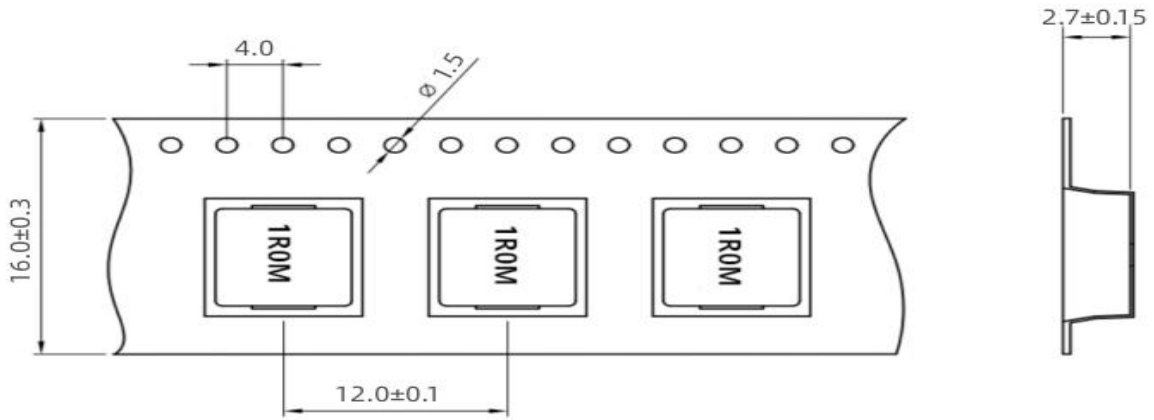

2.Reel

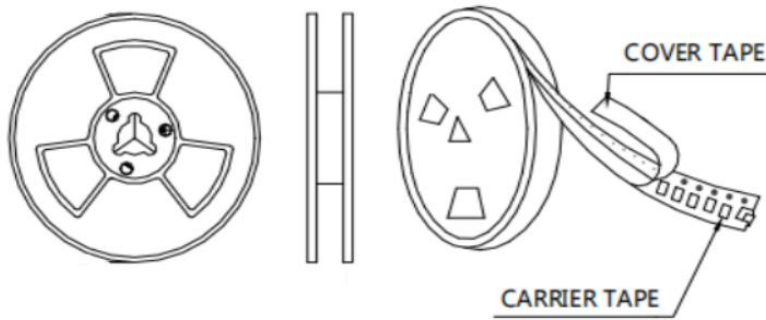

Part No.	Tape	MPQ
KMTC0620	Embossed Tape	2000PCS

Soldering Condition Sproduct

Applicable soldering process to the products is refl.

1.Soldering Materials

(1)Solder:Sn-3.0Ag-0.5Cu

(2)Flux:Use rosin-based flux,but not strongly acidic flux (with xhlorine exceeding 0.2wt%).Do not use water-soluble flux.

2.Reflow Soldering Profile

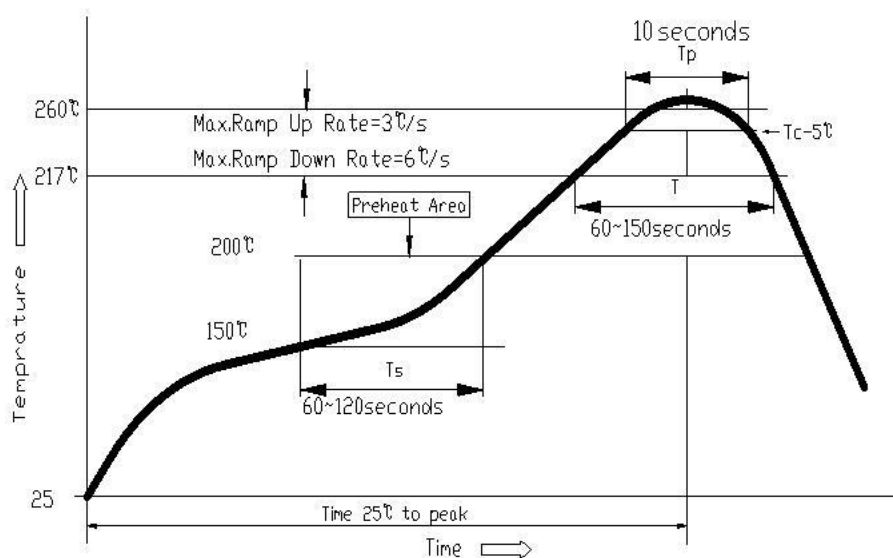

3.Solderin glron

Reworking with electric solding iron must preheating at 150°C for 1 minute is required,and do not directly touch the core with the tip of the soldering iron.The reworking soldering conditions are as follows.

- ①Temperature of soldering iron tip:350°C ;
- ② Soldering iron power output:≤30W;
- ③ Diameter of soldering iron end:≤1.0mm;
- ④Soldering time:<3s.

